

## Conventional Call Points



### Product Description

A comprehensive range of callpoints for use with FireClass conventional systems. All the callpoints are designed to enable an alarm signal to be given by breaking a glass element with the option of a resettable, deformable element. If required, an optional transparent hinged cover may be installed to guard against accidental operation.

### General Features

- Distinctive and recognisable styling
- Surface or Flush Mounting
- Test key facility, speeds maintenance visits
- Optional transparent hinged cover
- Optional Plastic Deformable Call Point Element for food processing areas
- IP67 Waterproof models for external application

### Product Codes

- 2501012** Conventional Manual Call Point with Glass Element (No Back Box)
- 2501013** Conventional Manual Call Point with Glass Element (With Back Box)
- 2501233** Conventional Manual Call Point with Plastic Element (No Back Box)
- 2501234** Conventional Manual Call Point with Plastic Element (With Back Box)
- 2501176** Conventional Weatherproof Manual Call Point
- 2501014** Spare Glasses for Manual Call Point (Pack of 5)
- 2501101** Manual Call Point Plastic Hinged Cover
- 2501040** Spare Manual Call Point Keys (Pack of 10)
- 515.001.127** Plastic Deformable Call Point Element

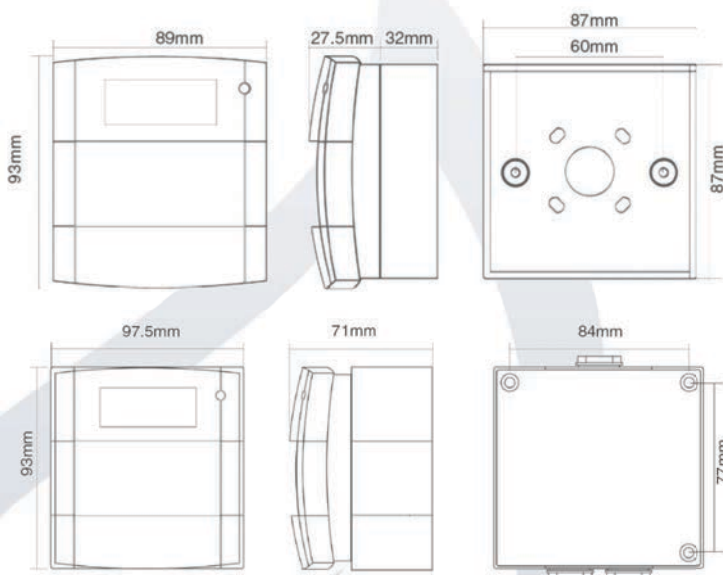

MODEL	DIMENSIONS (mm)	WEIGHT	OPERATING TEMPERATURE	RELATIVE HUMIDITY	I.P. RATING
<b>Indoor Conventional Callpoint</b>	93H x 89W x 59.5D (27.5 mm flush mount)	110g	-10° to +55°C	up to 95% RH non-condensing	24D
<b>Outdoor Conventional Callpoint</b>	93H x 97.5W x 73D	240g	-25° to +70°C	up to 95% RH non-condensing	67