

FC410QRM Quad Relay Module

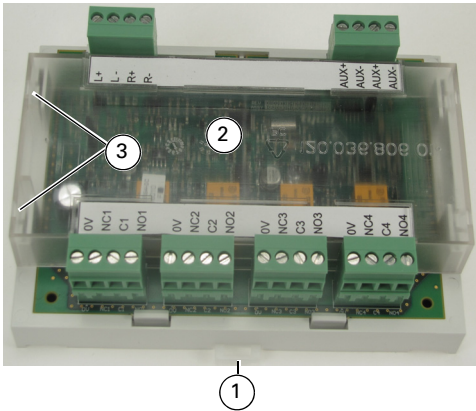

Fig. 1: FC410QRM Quad Relay Module

- 1– Release clip
- 2– Clear cover
- 3– Cover retaining tabs

Introduction

Figure 1 shows the FC410QRM Quad Relay Module, part number 555.800.773.

The module provides four potential free relay changeover outputs. The outputs are monitored, with parallel contacts of the relays. The outputs can be connected to an Auxiliary Voltage source and its voltage can be monitored.

Additionally, all the outputs are configurable to the HVR (High Voltage Relay) mode, which allows you to connect up to four HVR800 modules for switching; for example 240V loads galvanically isolated.

The module has an integral loop isolator. If this activates a yellow LED illuminates. The activation remains in place until the short is removed.

Installation Notes

The module is DIN rail mounted. This will typically be within a suitable enclosure, providing protection against mechanical shocks, electrostatic discharge and support for the cabling.

A suitable enclosure can be ordered under part number 557.201.410. This is rated to IP66, and is supplied complete with a mounting plate (Item 3 in Figure 2) and a piece of DIN rail.

Snap the FC410QRM module onto the DIN rail with the release clip protruding (Item 2 in Figure 2). The complete assembly is as shown in Figure 2.

For using another housing, ensure that it has a minimum weight of 0.8 kg with an IP rating of 20 or higher.

Refer to the section “Technical Specifications” to determine the required module configuration. Then connect the wiring and set the jumpers as appropriate.

Set an appropriate loop address for the module, using a FC490ST service tool. Use the module’s programming port, shown as Item 6 in Figure 3. To remove the clear plastic cover, release each of the four retaining tabs in turn (Item 3 in Figure 1). Use a screwdriver to press the tab inwards, while pulling upwards on the cover.

Select all cables in accordance with local standards, such as BS5839.

Check all conductors are free of earths.

If you need to remove the module from the rail, pull the DIN rail release clip (Item 2 in Figure 2).

Site Drawings

Once the address has been programmed, take note of the device location and address number, to include on site drawings.

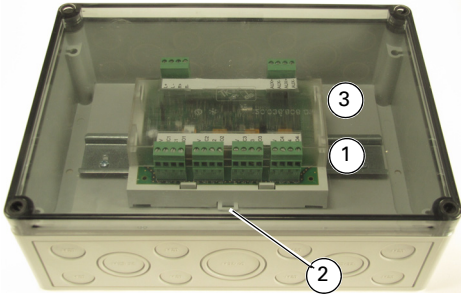

Fig. 2: FC410QRM Module fitted in the optional IP66 rated enclosure
 1– DIN rail
 2– DIN rail release clip
 3– Mounting plate

Technical Specifications

Table 1 shows the technical specification information.

Parameter	Value
Type Identification Value	167
System Compatibility	Use only with Fire-Class Fire Alarm Controllers
Environment	Indoor application only
Operating Temperature	-25 to +70 °C
Storage Temperature	-40 to +80 °C

Table 1: Technical Specifications

Parameter	Value
Operating Humidity	Up to 95 % non-condensing
Dimensions (HWD)	134 x 103 x 49 mm (including plastic housing and terminal connector)
Mounting Requirements	DIN rail/backbox surface mount
Battery Requirements	Standby current 1.1 mA Alarm current 5.9 mA
Wire Size	Min. 0.5 mm ² , max. 2.5 mm ²
Addressable Device Conditions	<ul style="list-style-type: none"> ■ Normal ■ Active ■ Auxiliary Voltage Fault ■ Relay Stuck Fault ■ Isolator Fault ■ Device No Response
Device Mode for each Single Output Point (Selectable by panel configuration software)	<ul style="list-style-type: none"> ■ Door Control ■ Alarm Control
Electromagnetic Compatibility	<ul style="list-style-type: none"> ■ EN50130-4 for immunity ■ EN61000-6-3 for emissions

Table 1: Technical Specifications (cont.)

Features

Output Circuit (Relay Contact)

- Nominal switching capacity 2 A 30 VDC (resistive load)
- Max. switching power 60 W, 125 VA (resistive load)



WARNING

Danger from Electric Shock

Do not use the relay contacts to switch the mains voltage.

Auxiliary Voltage Input

- Auxiliary voltage 24 VDC max 55 VDC (Threshold voltage for auxiliary voltage fault indication: 18 VDC \pm 1 V)
- Auxiliary voltage 48 VDC max 55 V DC (Threshold voltage for auxiliary voltage fault indication: 36 VDC \pm 2 V)

Terminals

Table 2 shows the terminal information.

Description	Marking	Comment
FireClass Loop Interface	L+	Loop+ to left
	L-	Loop- to left
	R+	Loop+ to right
	R-	Loop- to right

Table 2: Terminals

Description	Marking	Comment
Auxiliary Voltage Input	AUX +	Auxiliary Voltage input + (both in parallel)
	AUX -	Auxiliary Voltage input - (both in parallel)
	AUX +	Auxiliary Voltage input + (both in parallel)
	AUX -	Auxiliary Voltage input - (both in parallel)
Relay Output 1 Relay Output 2 Relay Output 3 Relay Output 4	NC1 NC2 NC3 NC4	Normally closed contact
	C1 C2 C3 C4	Common contact
	NO1 NO2 NO3 NO4	Normally open contact
	OV	Connected to AUX -

Table 2: Terminals (cont.)

Jumpers

Table 3 shows the jumper information.

Jumper	Description
ISO. ON/ISO. OFF	Isolator Activated/ Deactivated Connect either link depending on whether or not the Isolator function is required.
Auxiliary Voltage	Nominal value 2-3 24 V DC, 1-2 48 V DC
OUT1 OUT2 OUT3 OUT4	HVR 1-2= HVR compatible, AUX 2-3= C1/C2/C3/C4 connected to AUX +, not fitted = general voltage free relay output. The HVR option is not permissible if a 48 V DC Auxiliary Voltage is connected.

Table 3: Jumpers

Indicators

Table 4 shows the Indicator information.

Indicator	Description
ISO.	ON = Isolator active
OUT1	ON = Relay Output 1 is set
OUT2	ON = Relay Output 2 is set
OUT3	ON = Relay Output 3 is set
OUT4	ON = Relay Output 4 is set
POLL	<ul style="list-style-type: none"> ■ Flash = Poll of module ■ Steady ON = At least one relay is activated

Table 4: Indicators

The values for the indicators OUT1, 2, 3, 4 and POLL depends on the software configuration.

Wiring Diagrams

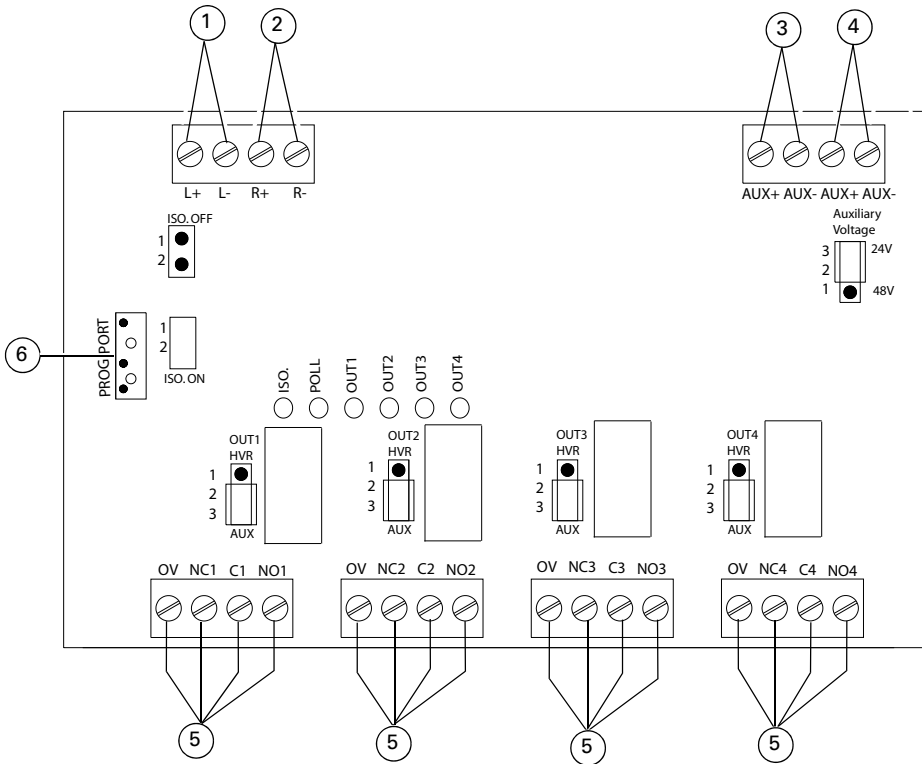

Fig. 3: Terminal Arrangement

1– From FireClass Control Panel or Previous Loop Device

2– To Next Loop Device

3– From FireClass Control Panel or External Power Supply

4– To Next FireClass Device

5– Four Off Configurable Voltage Free Relay Outputs or HVR Drivers or 24 VDC/48 VDC Auxiliary Voltage Supply

6– Address Programming Port

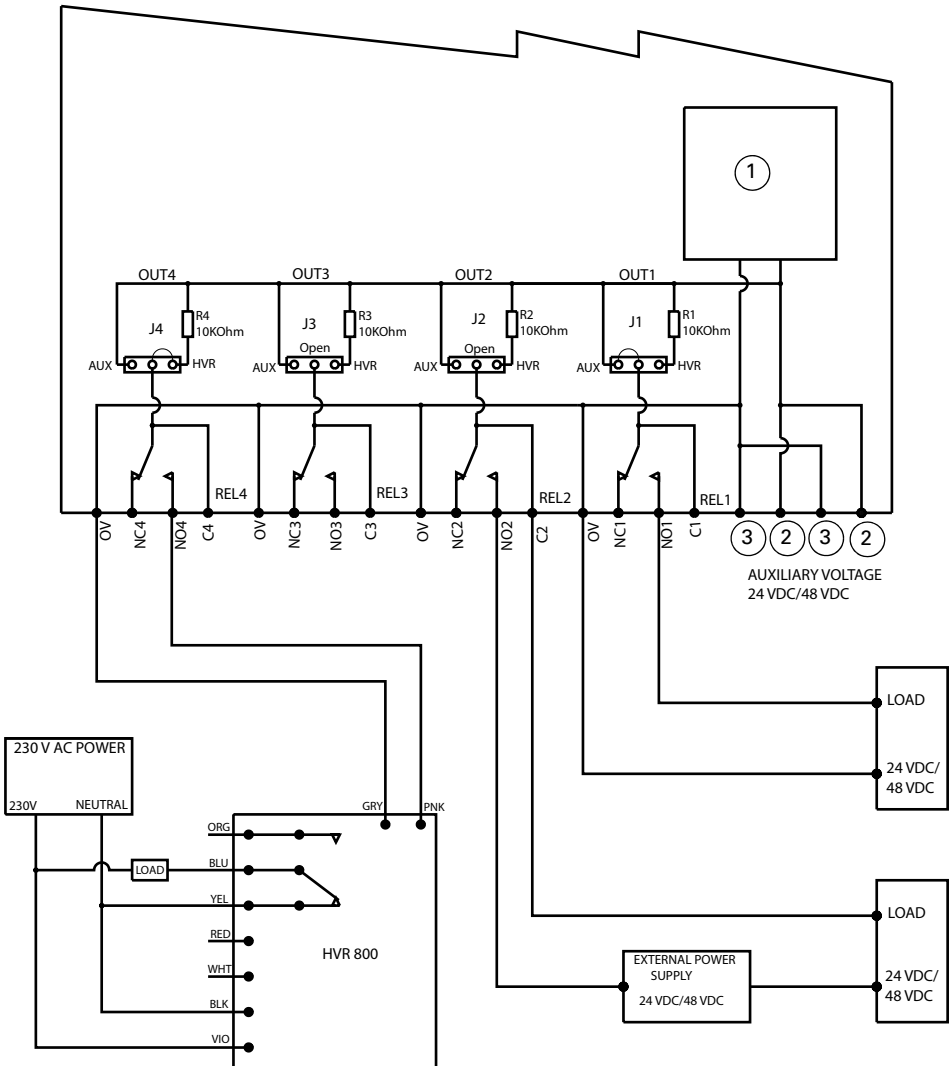



Fig. 4: Terminals

- 1- External Voltage and Wire Monitor
- 2- Positive External Voltage
- 3- Negative External Voltage

Jumpers J1, J2, J3 and J4 must be set according to Table 3 on page 4.

CPR Information

<p>Tyco Fire & Security GmbH, Victor von Bruns-Strasse 21, 8212 Neuhausen am Rheinfall, Switzerland</p> <p>15 0786-CPR-21158 22 0832-UKCA-CPR-F0146 DoP-2015-4090</p>
<p>EN54-17 and EN54-18 Input/Output device with Short-Circuit Isolator for use in fire detection and alarm systems in buildings FC410QRM</p>
<p>Essential Characteristics EN54-17 and EN54-18 Performance under fire conditions: Pass Operational reliability: Pass Durability of operational reliability; temperature resistance: Pass Durability of operational reliability; vibration resistance: Pass Durability of operational reliability; humidity resistance: Pass Durability of operational reliability; corrosion resistance: Pass Durability of operational reliability; electrical sta- bility: Pass EN54-18 Response delay (response time): Pass</p>
<p>Isolator Specification Guide A16381RMK0_EN</p>

