

NF2000 & NF3000

H A R D W A R E

version 2.8.1

Honeywell

Modular build

NF2K & NF3K



Honeywell

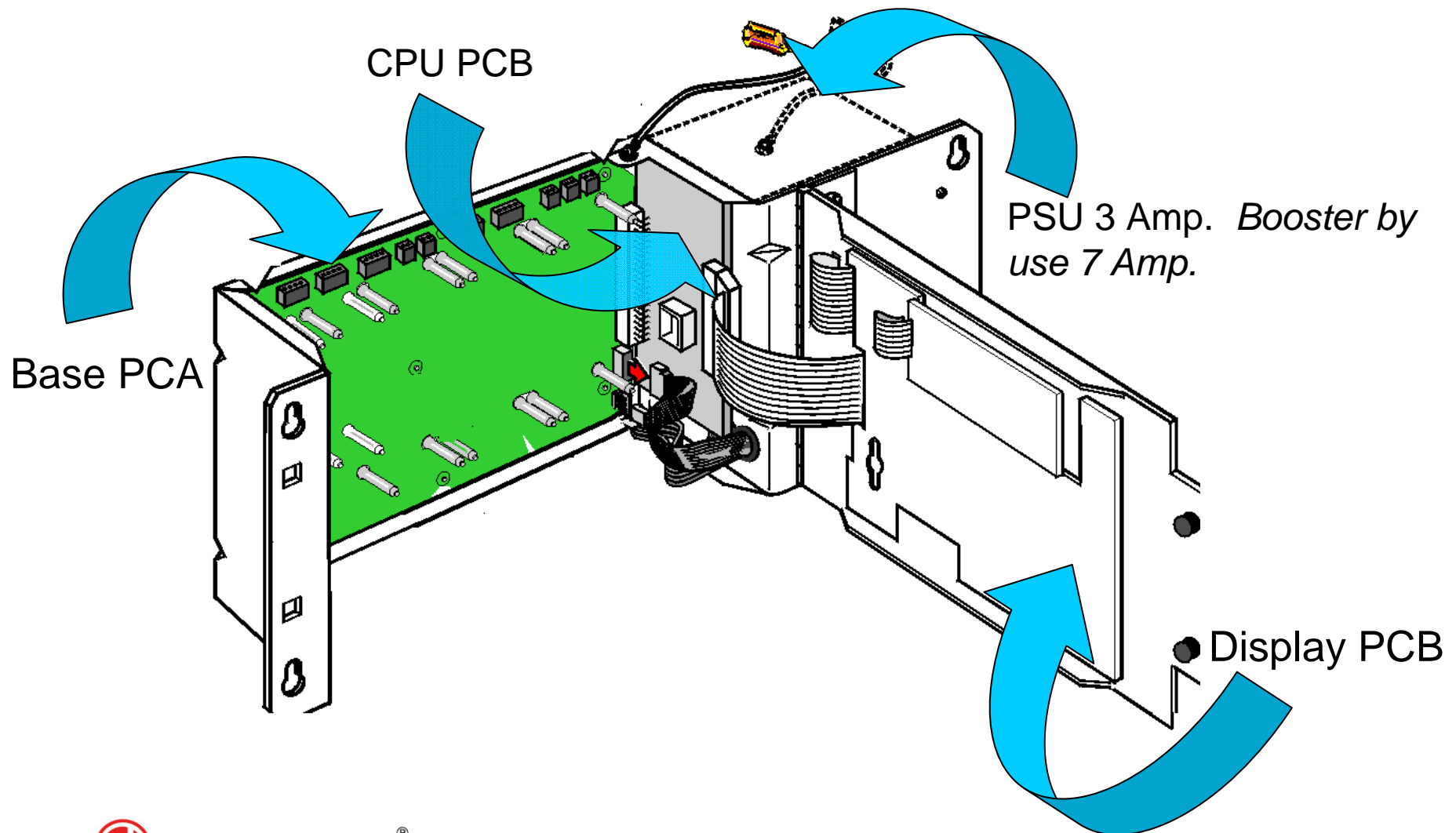

Main PCB NOT CPD

NF2K & NF3K



Honeywell

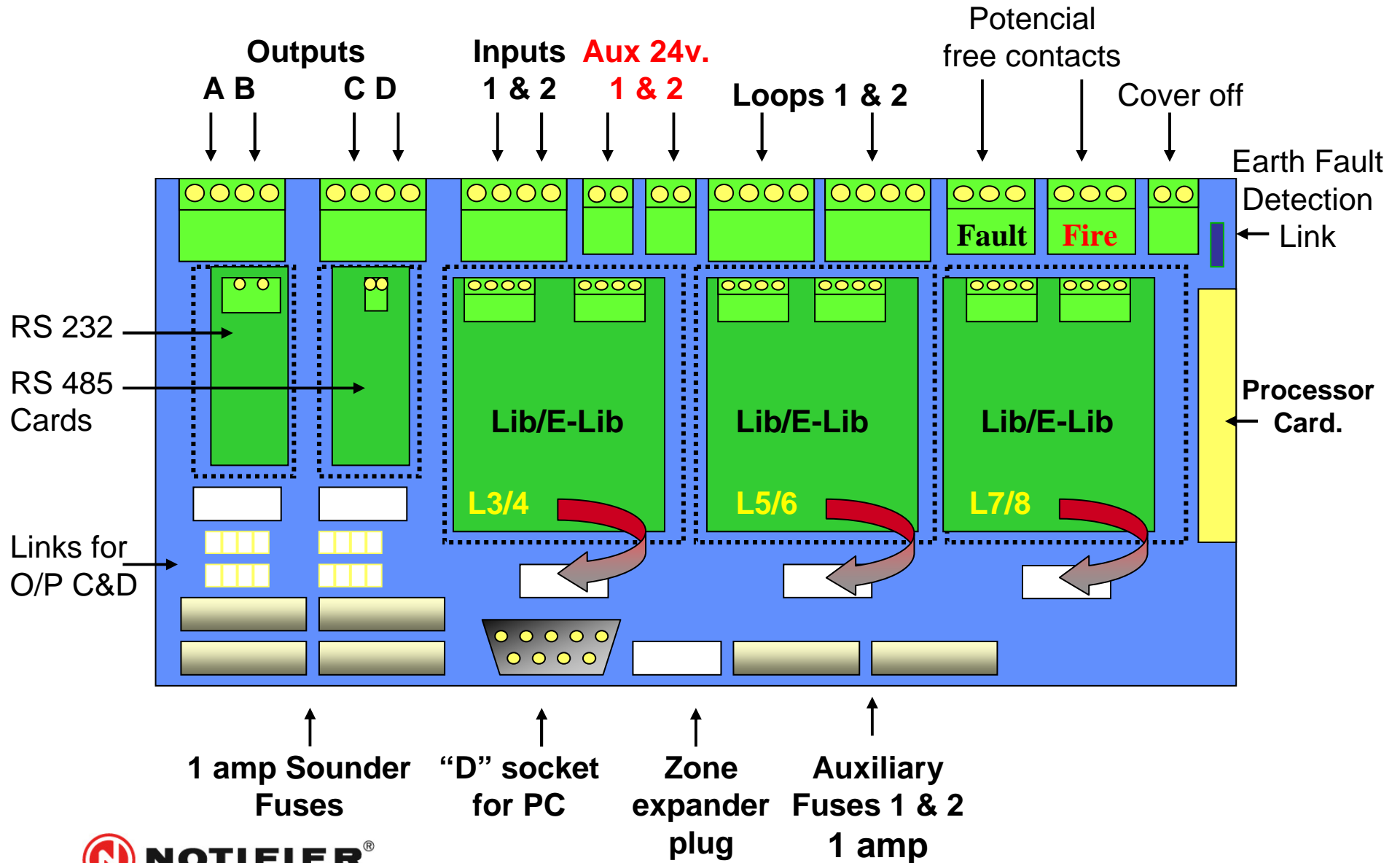

Main PCB CPD

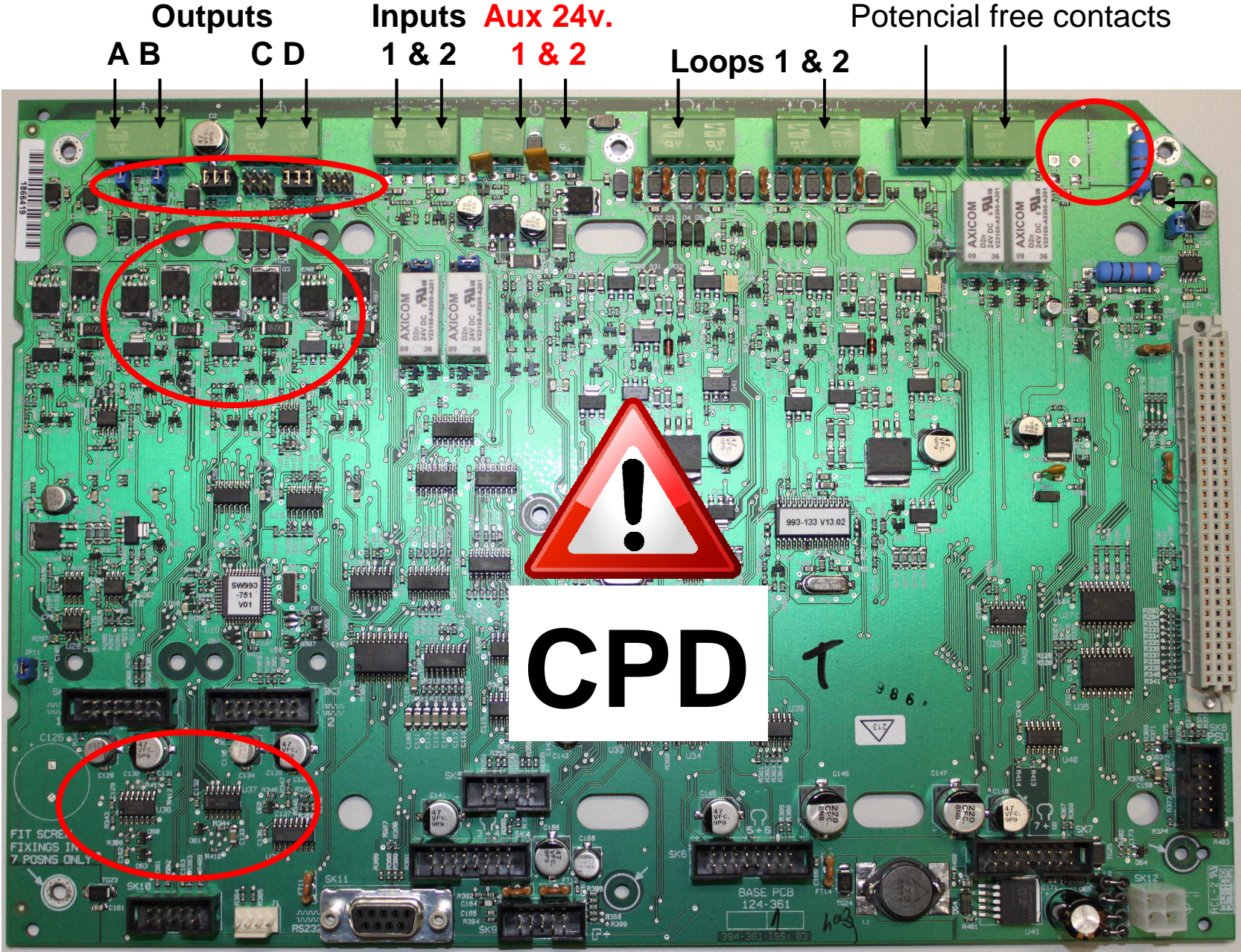

New Main PCB Programmable Outputs CPD

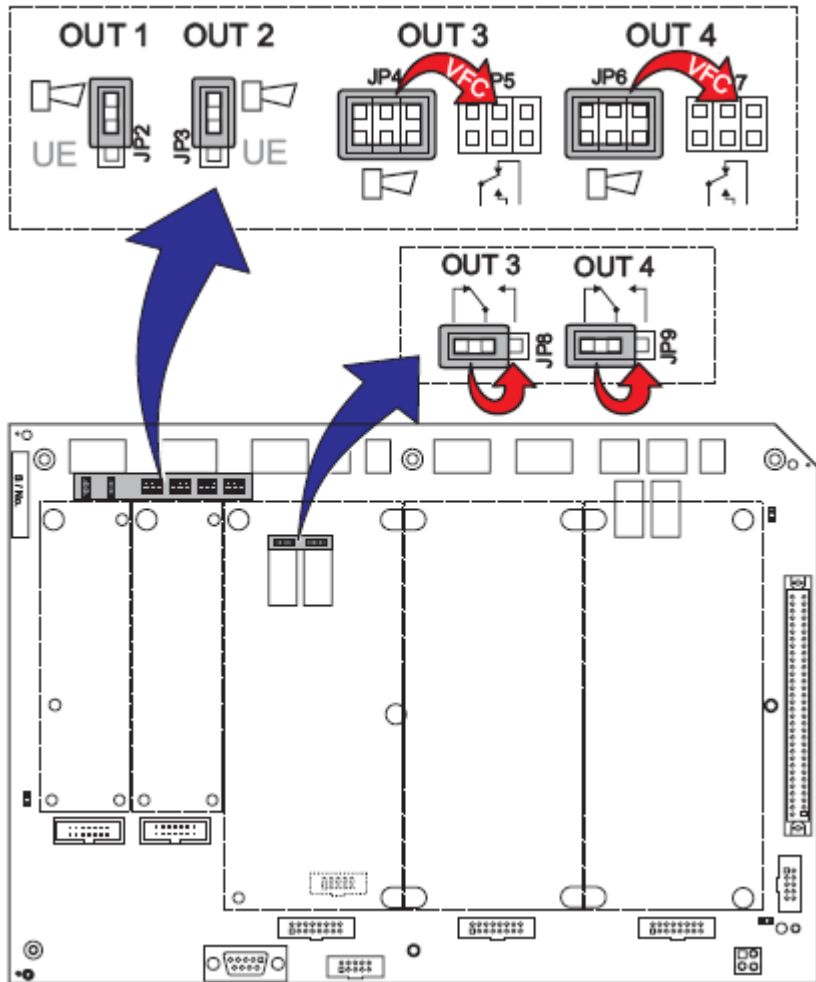

Output	Fit Jumper Links over:	For Normally Open	For Normally Closed
3	JP5 JP8 →		
4	JP7 JP9 →		

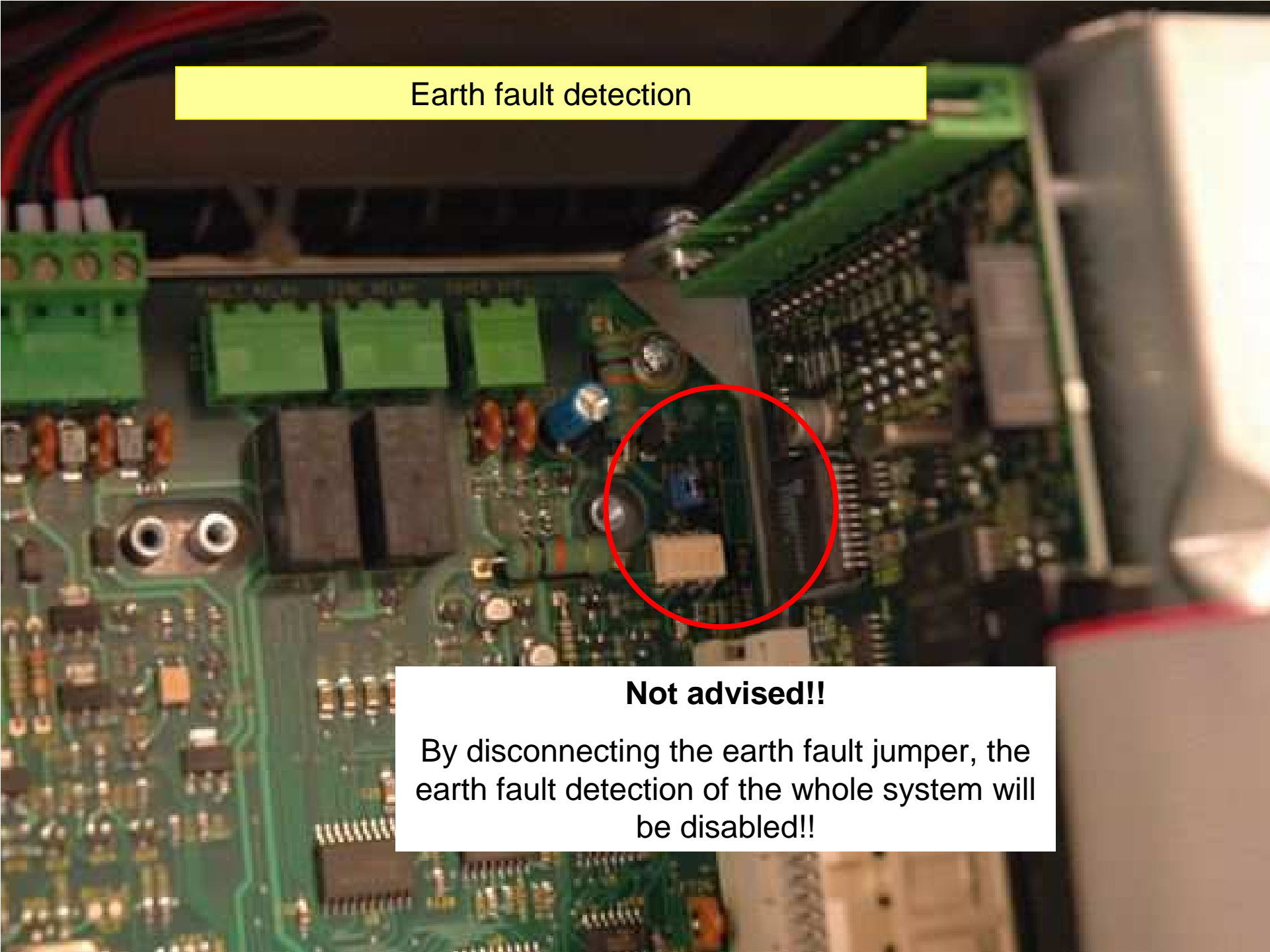

Earth fault detection

Not advised!!

By disconnecting the earth fault jumper, the earth fault detection of the whole system will be disabled!!

Main PCB Programmable Outputs

NF2K & NF3K



Honeywell

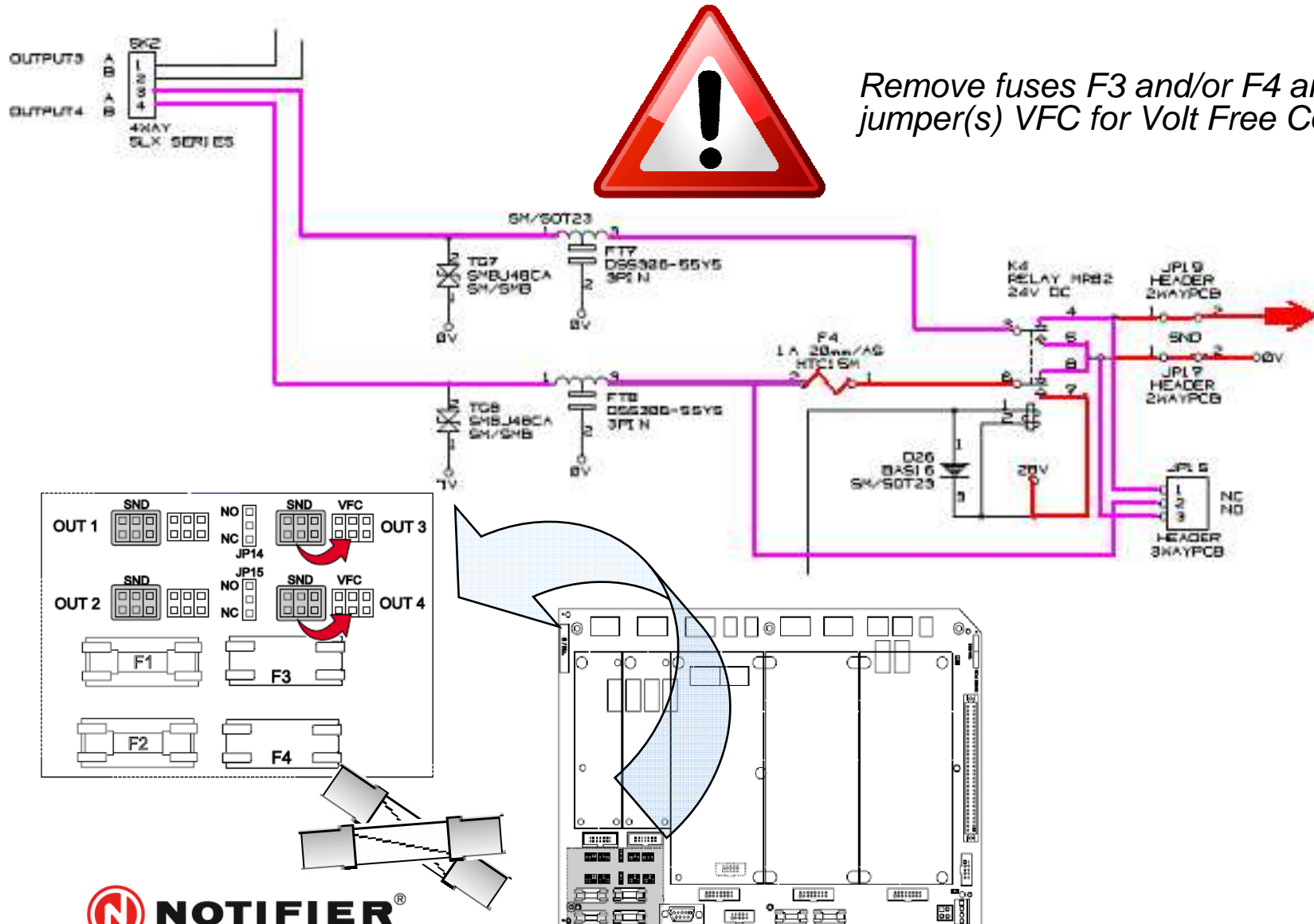

CPU Board

PROCESSOR CARD

Mounted between Base PCB and frontpanel

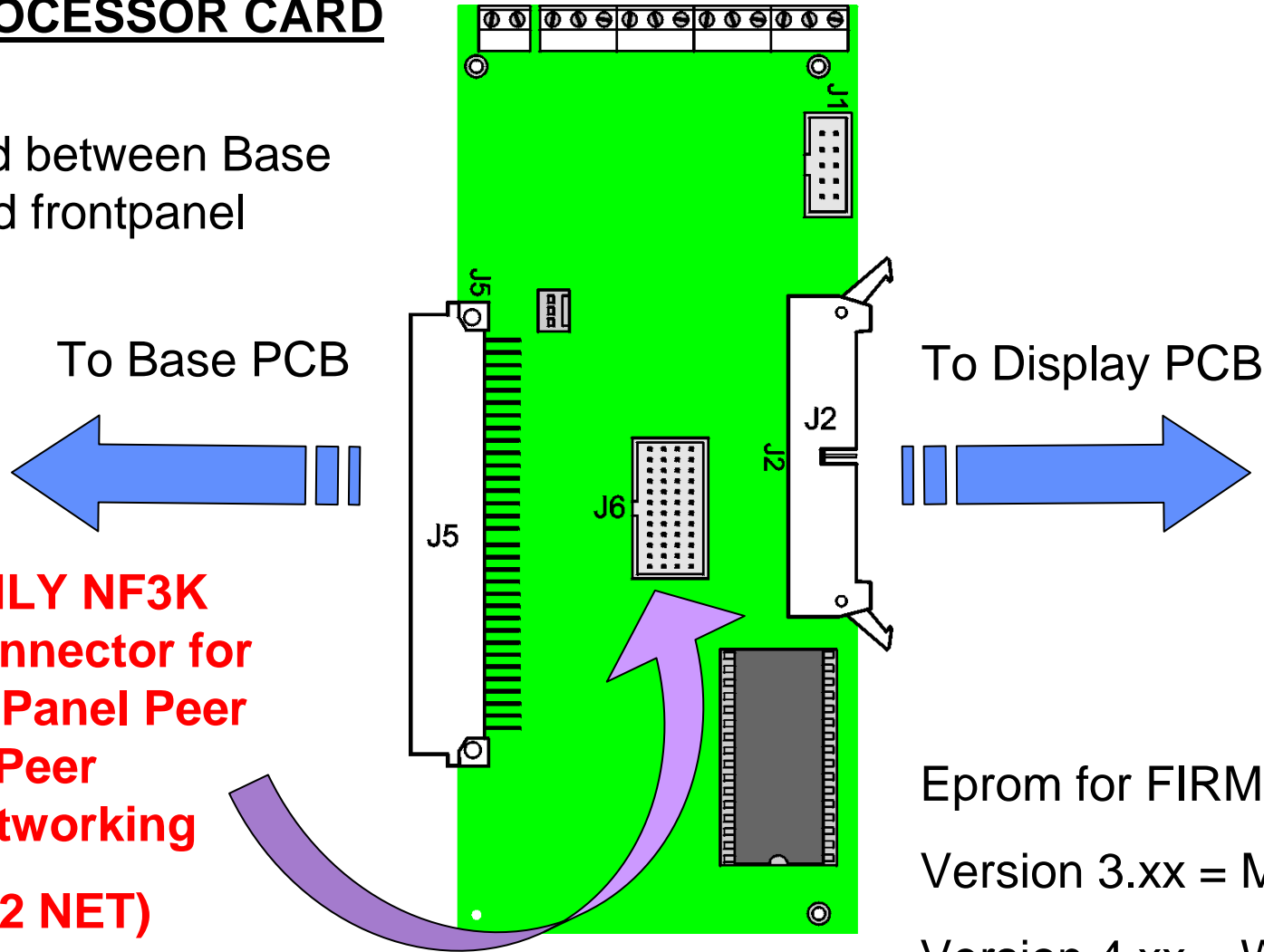

**ONLY NF3K
Connector for
32 Panel Peer
to Peer
Networking
(ID2 NET)**

Eprom for FIRMWARE
Version 3.xx = MS DOS
Version 4.xx = Windows

CPU Board

NF2K & NF3K



Honeywell

Connection details NF3000-CPU board

- 1 0 volts
- 2 +5 volts output
- 3 Output FAULT LED (606)
- 4 Output ALARM LED (607)
- 5 Output not used (605)
- 6 Input Enabling Key Switch (84/92 - I/P 93)
- 7 **Output DAY MODE LED (604)**
- 8 **Input Day Mode Switch (83/91)**
- 9 **Input Reset Switch (82/--)**
- 10 Input Mute/Silence etc. Switch (81/89)
- 11 Input not used (80/88)
- 12 Output TX O/P ACTIVATED LED (603)
- 13 Output not used (CS2PORT bit 0)
- 14 no connection

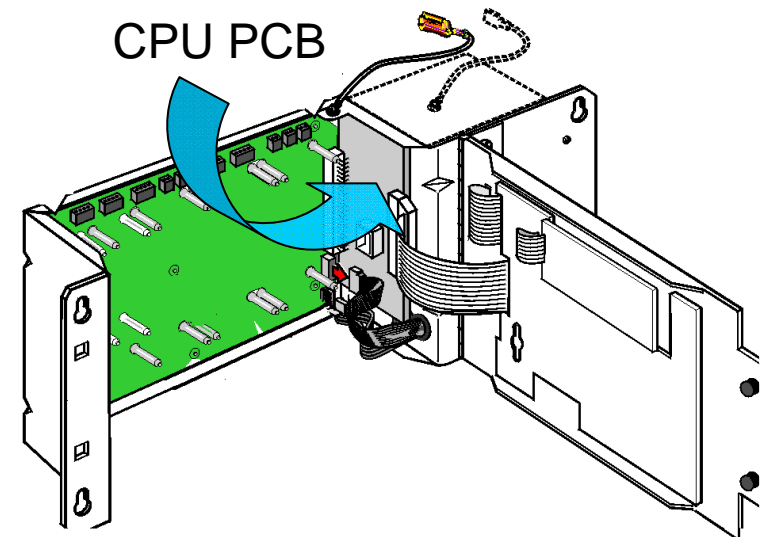
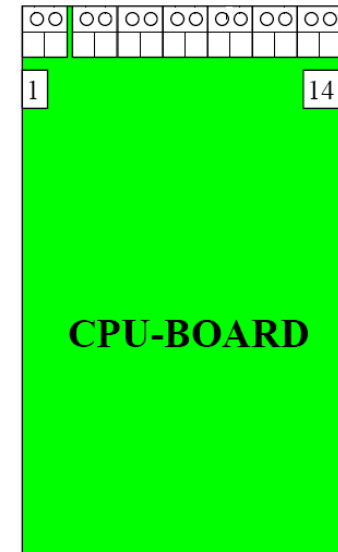

Connection on CPU only available in Swiss mode

Display Contrast NF3000

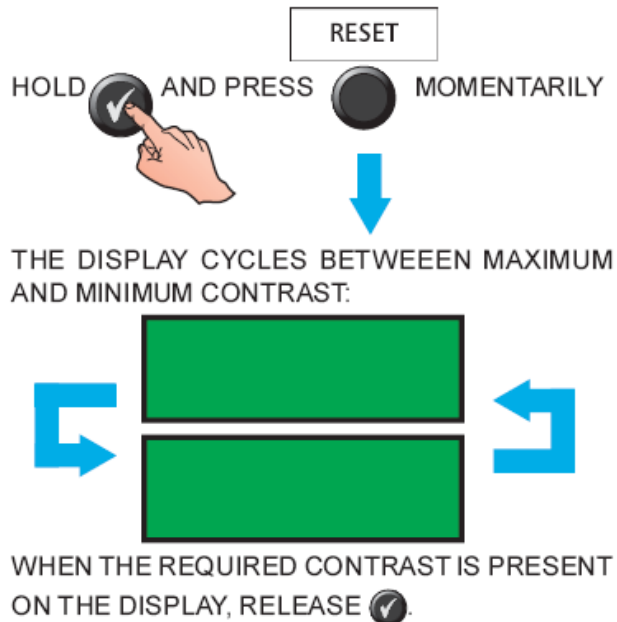

3.3.2.1 LCD Contrast Adjustment

This adjustment procedure as shown at left is only available within the first two minutes after power is applied to the panel.

To adjust the LCD contrast at other times, select LAMP TEST (refer to the ID3000 Series Operating Manual 997-275-XXX, Section 6.4 Lamp Test) while at access level 3. Hold while the test progresses. The contrast then cycles and the remainder of the procedure is as shown at left.

TO FINE-ADJUST, USE:



WHEN COMPLETED, PRESS:



TO INVOKE THE SELECTED CONTRAST VALUE.



It's possible by the first panel power up that the display needs contrast adjustment.

Housing

NF3000 Different housing

Honeywell



NF3000 has 255 zones, indicated in display instead of seperate leds

NF3000 CAB D2



NF3000 CAB C2



NF3000 CAB B1



Different housing

CAB B1

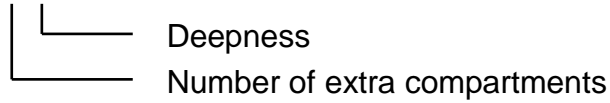

B=1, C=2, D=3

Deepness 1=122mm 2= 220mm (deepbox



CAB B1



CAB C1



CAB C2



CAB D2



CAB D1



Deepbox for 7 Amp. Powersupply with booster.



Modular build

NF2K & NF3K



Honeywell

Panel Printer + 255 Zones Supported in 19" Rack Panel.

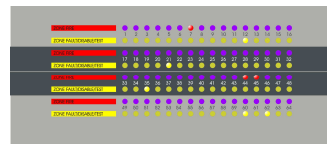
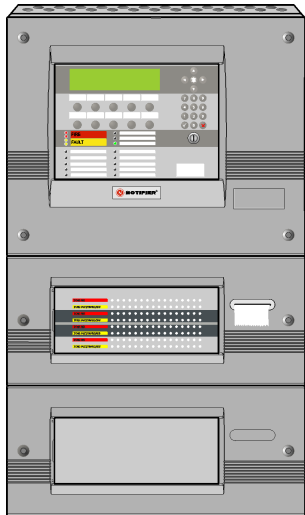

64 Zones + Printer

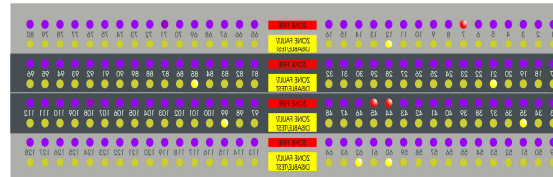

128 Zones + Printer

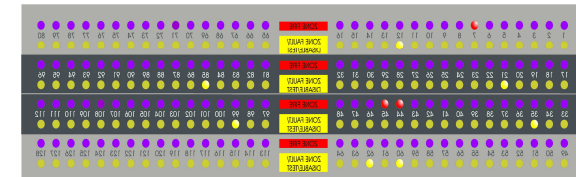
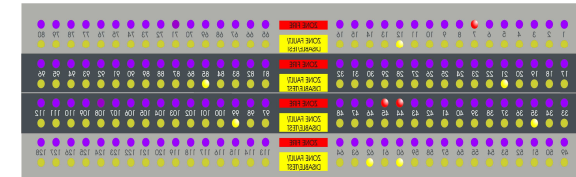

255 Zones + No Printer
(external printer 🖨️)

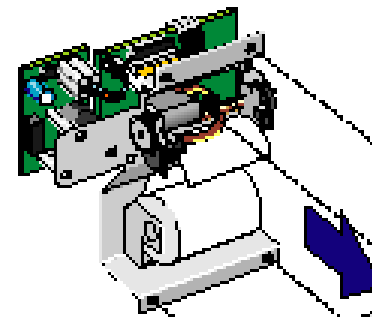
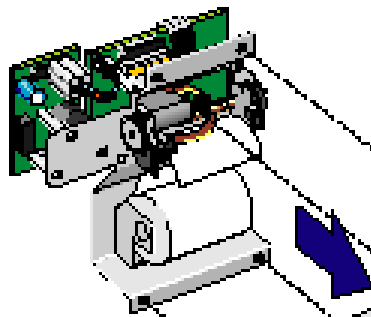

Loops



Loops and limitations

A NON fixed system can be extended up till 8 loops.

Each loop can hold an maximum of 99 detector and 99 Modules
(depending of Cable length and load)

- **M**aximum Loop resistance: 40 Ohm
- **M**aximum Loop capacity: 0,5qF
- **T**wisted Cable for reducing influences

A individual loop, supply a maximum loop current of 500mA
(depending from PSU and overall system power consumption)

Each Panel (cpu) can handle a legal quantity of 512 devices. To add more devices, an special loopcard with CPU is needed (Elib)

Noise in straight and twisted pair cables

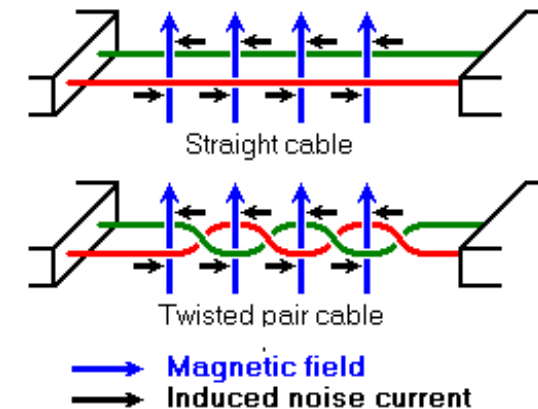

Loops and limitations

NF2K & NF3K



Honeywell

Notifier Loop And Battery Calculator

File Settings View Tools Help

Loops(2)
 Loop1
 SDX-751 (Optical smoke sensor)
 SDX-751 (Optical smoke sensor)
 SDX-751 (Optical smoke sensor)
 SDX-751 (Optical smoke sensor)
 SDX-751 (Optical smoke sensor)
 SDX-751 (Optical smoke sensor)

Group: []

Explorer Panel Settings Battery

Untitled

Loop1 Cable characteristics

Dual Device Detection

Number of External LEDs: 0

Other Loop Current (average), mA
 Quiescent: 0 Alarm: 0

Add/Remove Device(s)

Total Load (average), mA
 Quiescent: 24.9 (10%) Peak: 49.80
 Alarm: 152.7 (59%) Peak: 293.65
 Exceeded

Max Loop Resistance and Length
 Maximum supportable resistance of negative conductor, Ohm: 22
Limited to ensure dual device dr
 Limited to ensure commu
 Maximum allowable cable length, m: 1841
 Single Cable Fault: SUPPORTED Limited to

Part Number	Otv	Mode	Short Description	Is		
Loop1	1.50	24.90	152.70	OFF	23	1842
Loop2	1.50	0.00	0.00	OFF	--	--

Calculations Results and Loop Summary

Total Panel Current, mA
 Quiescent: 189.9
 Alarm: 407.7
 Exceeded

Battery
 Min Size, Ah: 14.23
 Auto selection
 Exceeded

Ready

Elib during normal operation

NF2K & NF3K



Honeywell

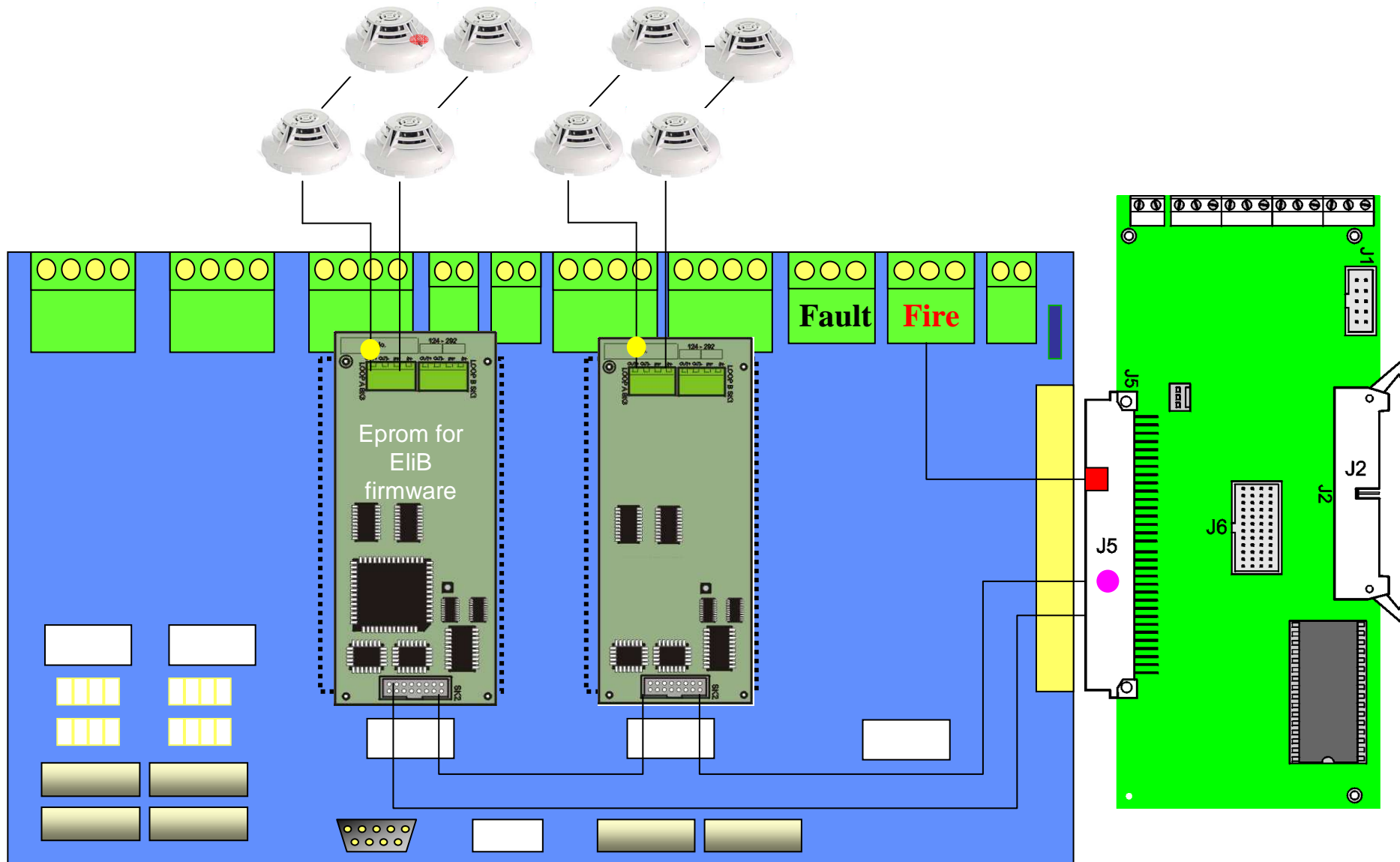

Elib during CPU failure

NF2K & NF3K



Honeywell

Only output a,b,c,d will be activated by Elib during fire



By using Elib, transmission should ALWAYS be activated by relay a,b,c or D

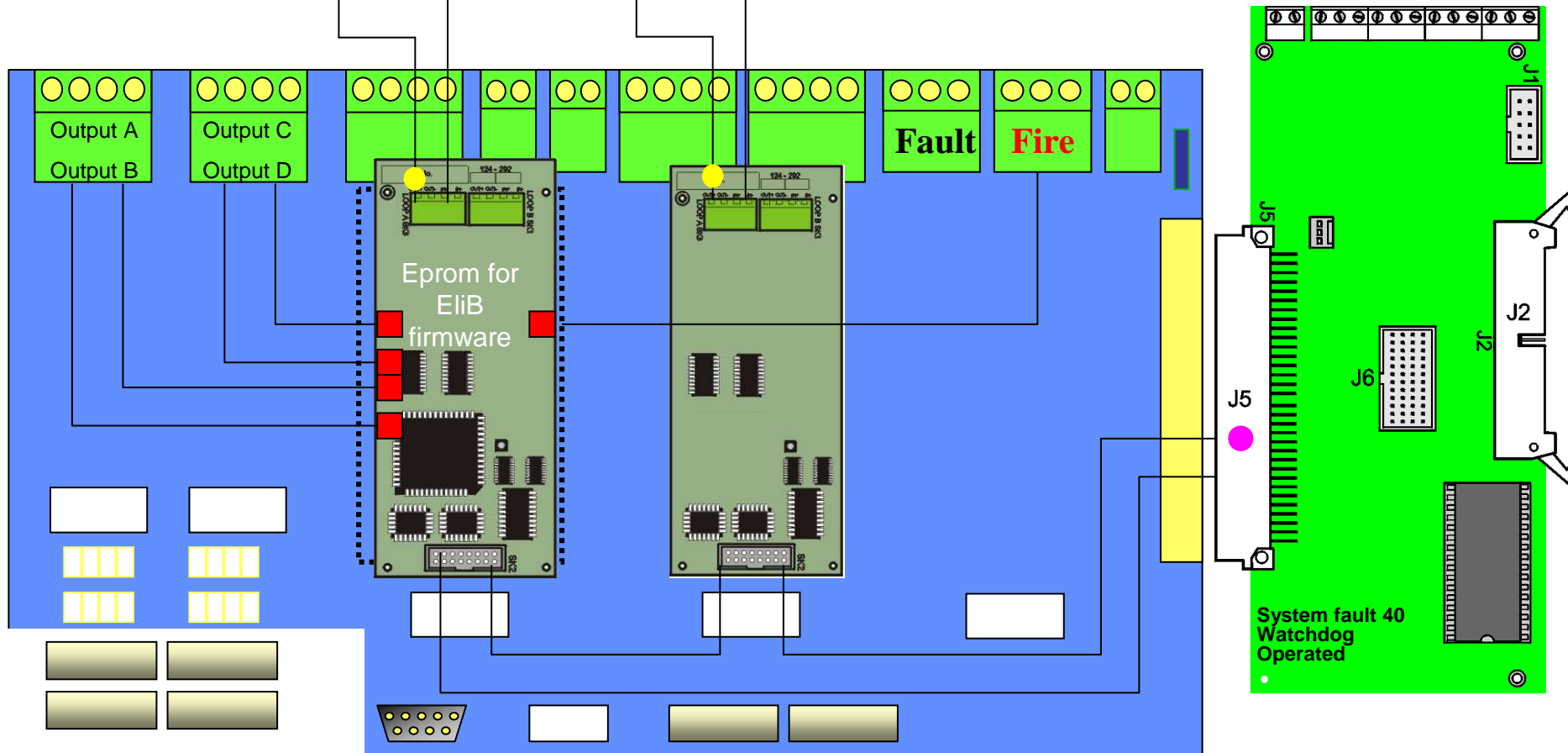

Loop polling behavior

NF2K & NF3K



Honeywell

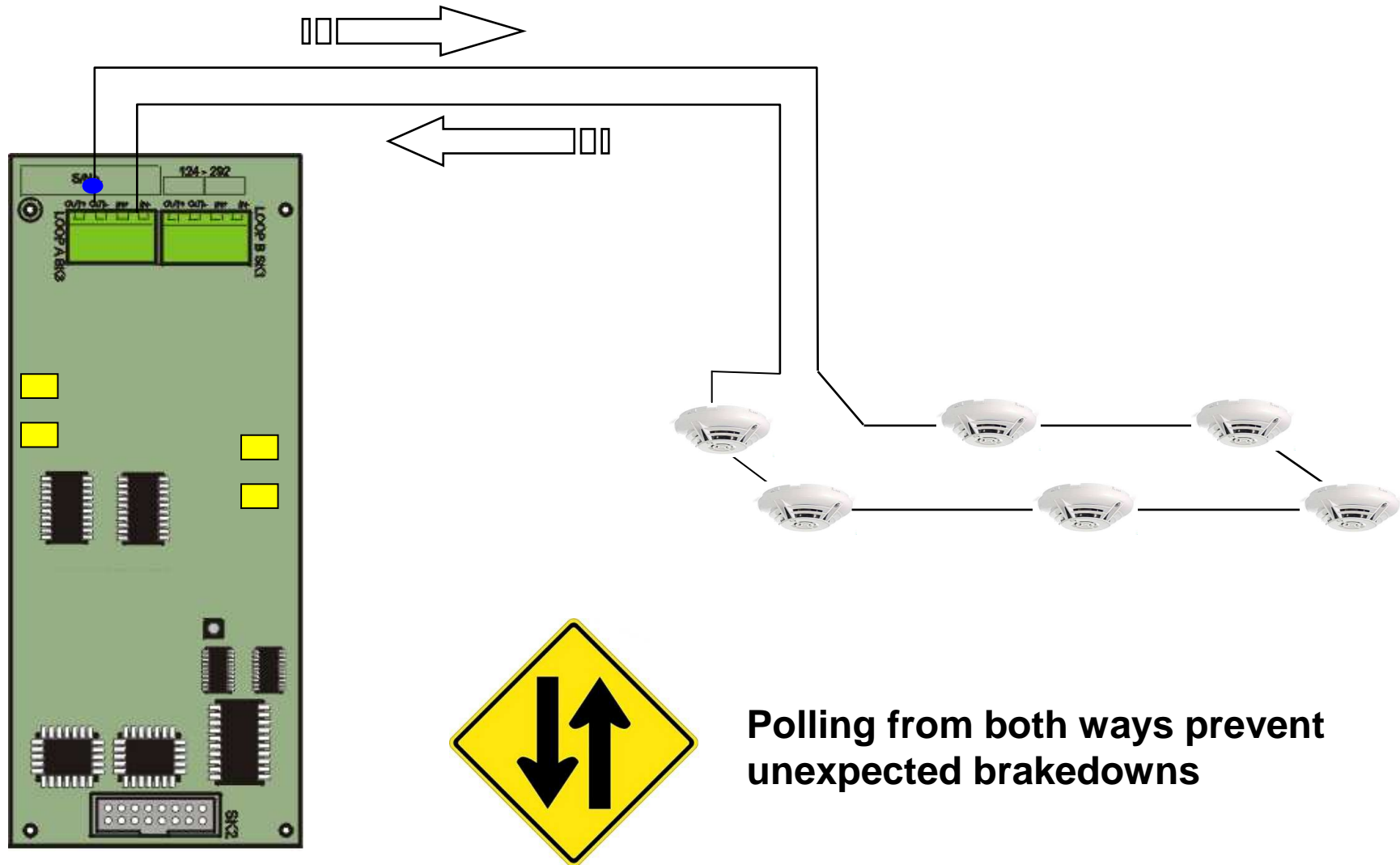

Polling from both ways prevent unexpected brakedowns

Loop polling behavior

NF2K & NF3K



Honeywell

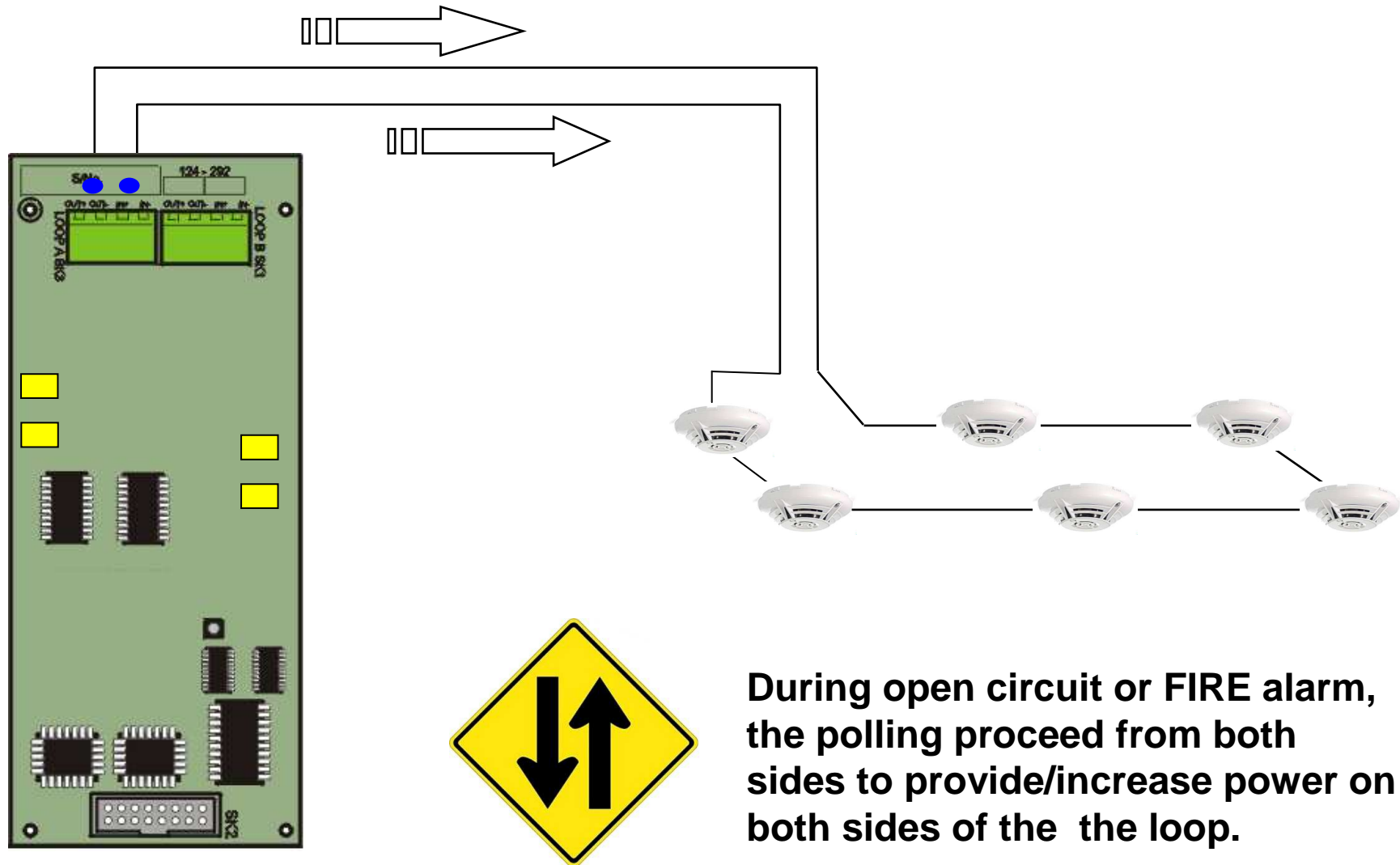

Bad Polling

Every miscommunication between panel and loop device / peripheral is logged in the “Bad polling” Log.

Increasing the counter means bad communication between panel and components

```
Log/display/print menu
▲ 2:Print device data
  3:Display/print event log
  4:Printer Control
▼ 5:Display bad poll log
Service/ Mon 01-May-2000 11:20:07
```

```
BAD POLL LOG
Loop polls:
L1:n    L2:n    L3:n    L4:n
RS485: nn
Fault/Service/ Mon 01-May-2000 11:20:07
```

**Access Level:
84373**

Power supply

Power supplies

NF2K & NF3K



Honeywell

Two different types of power supplies are available :

7Amp. + Dual path Booster

3 Amp. standard

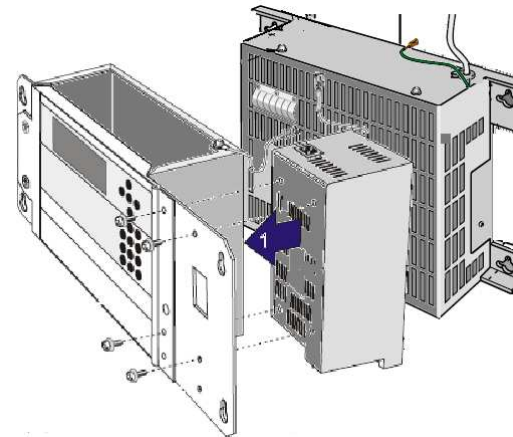
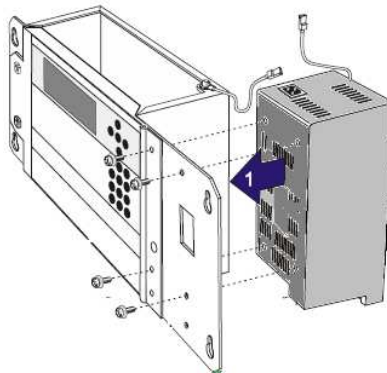

**130Ah batteries
are stored
EXTERNALLY**

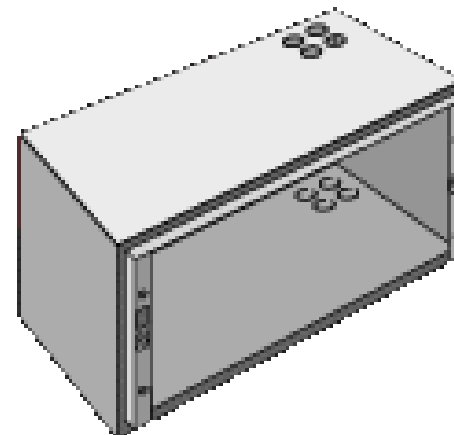

Power supplies

NF2K & NF3K



Honeywell

Power FACTS:

- Battery discharging under 21volt, power supply switch-off recharging!
(avoid system male-function and deep discharging)
- No battery charging during Alarm, Tech alarm configurable on panel (Recommended)
- Battery charging switch-off by disconnecting batteries.
- Charging voltage temp. controlled by NTC
- Power-up system, first connect Mainpower, second connect the Batteries.



Connector and Mounting



Older Power supply's were provided with a 4 pins bar connector. Latest PCB's are provided with both connectors. (downwards compatible)

Replacing power supply on older systems, mounting adaptor plate is necessary !

Input

Voltage, frequency: 230Vac, $\pm 15\%$, 50/60Hz.

Maximum current consumption: 1,6 (protected by 5A)

Output

Voltage.(Boosted) 26-29 volt

Ripple Voltage $\pm 300\text{mV}$

Max output Current Quiescent 700mA

Max output current Alarm 3A

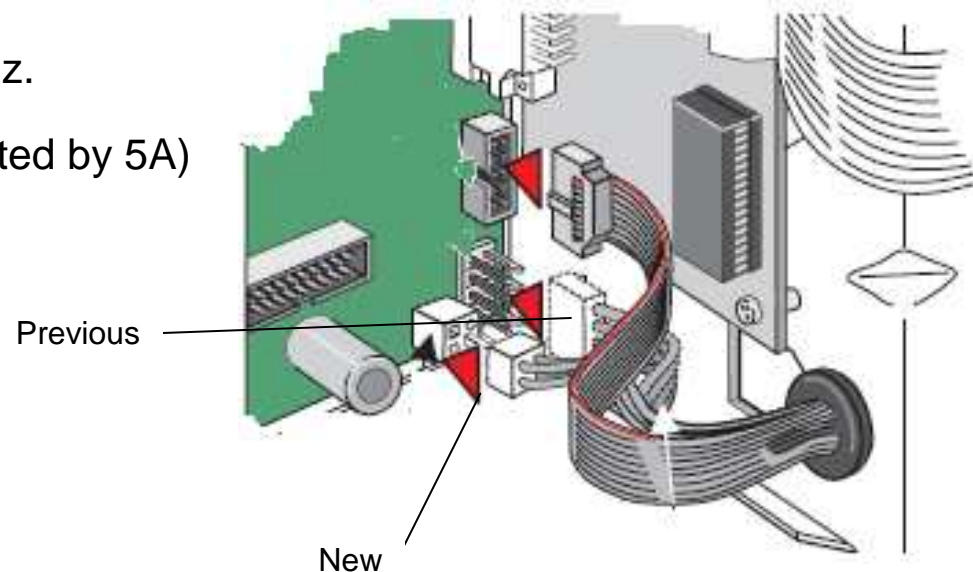

P.S.U 7A + Booster

NF2K & NF3K



Honeywell

Connector and Mounting



Power supply's mounted backside of cabinet and **deep-box** required

Belgium's regulation requires an extended, separated box to comply Bosec approval

Input

Voltage, frequency: 230Vac, $\pm 15\%$, 50/60Hz.

Maximum current consumption: 3A (protected by 5A)

Output

Voltage.(Boosted) 26-28 volt

Ripple Voltage $\pm 300\text{mV}$

Max output Current, see next slide

Max output current, see next slide.

Battery Charger Output Rating

Battery voltage when charged: 27.3V at 20°C (Charge float voltage)

Temperature compensation: $-3\text{mV}/^\circ\text{C}/\text{cell}$

Battery fuse rating: 8A. 250VHRC(F)

Final battery voltage: 21V

Charger ripple voltage: $\pm 20\text{mV}$

P.S.U 7A

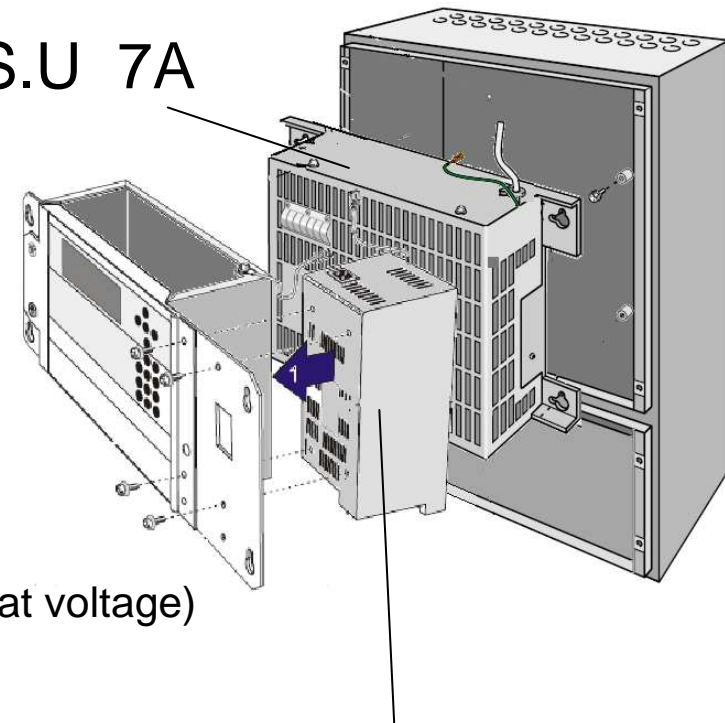

Dual Path Booster

P.S.U 7A + Booster

PSU and Battery Enclosure		Battery Capacity ¹	Charge Current	Alarm Current ²	Quiescent Current ²
Description	Part Number				
Deep back box	020-474-XXX or 020-475-XXX	42Ah ³	2.5A	4.5A	2.5A
External battery box	020-541-XXX	42Ah	2.5A	7.0A	4.0A
External battery box	020-541-XXX	78Ah	4.5A	7.0A	3.0A
2 external battery boxes	020-541-XXX (x 2)	130Ah	7.3A	7.0A	1.5A

¹ Charged to 80% within 24 hours.

² Currents in this table refer to the maximum current available at the output of the DTP/Booster.

³ Refer to instruction sheet 997-270 for the sizes and battery capacity of other enclosures.

P.S.U 7A + Booster

NF2K & NF3K



Honeywell

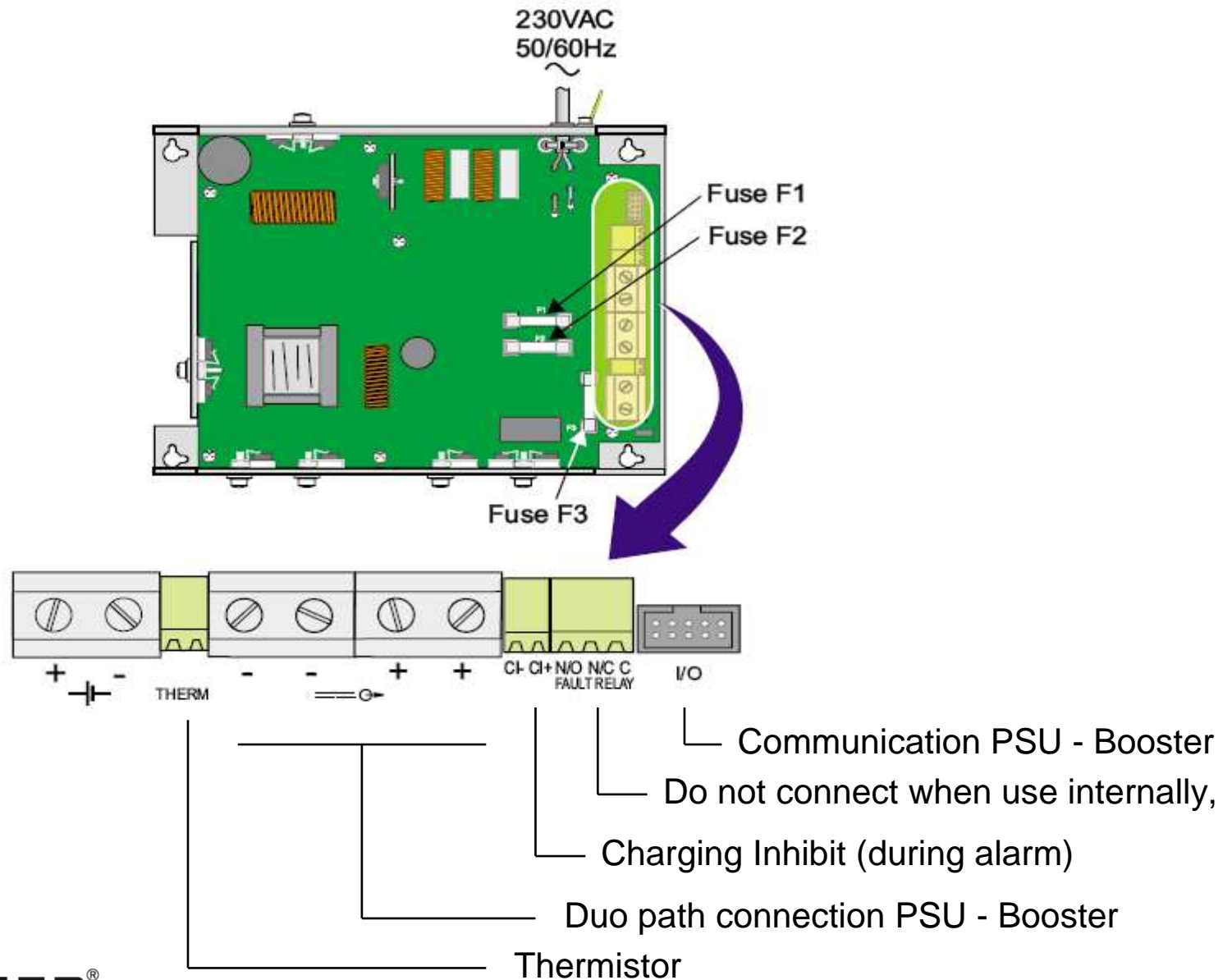

P.S.U 7A + Booster

NF2K & NF3K



Honeywell

IMPORTANT NOTE when using 130Ah Battery Back Up...

To ensure correct operation of the PSU7A when used with 130Ah back up batteries, two remote enclosures **MUST** be used. The PSU7A must be installed in one enclosure and **ALL** the batteries must be installed in the other enclosure. For further details when using the 130Ah batteries, refer to instruction sheet 997-270.

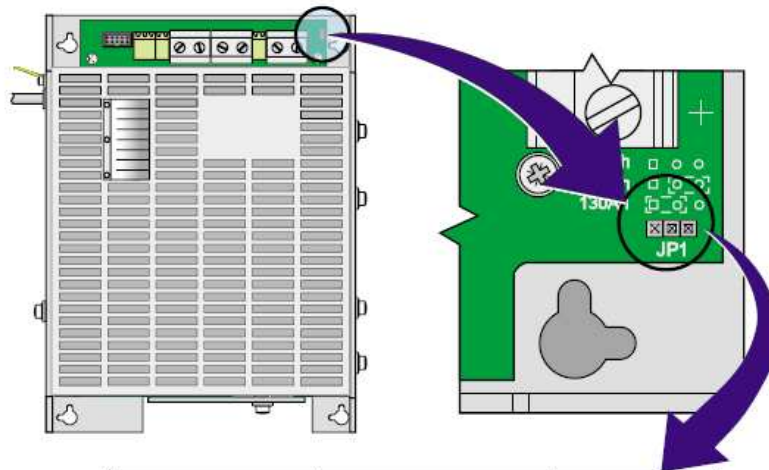

Backup Batteries (Ah)	Jp1 Link Position	Pin Nos.
42		Not fitted
78		2 & 3
130		1 & 2



P.S.U 7A + Booster

F = RS-485 (INTERNAL - NOT FOR NETWORKING)

G = BATTERY MONITOR

H = CHARGER INHIBIT

I = COMMON FAULT

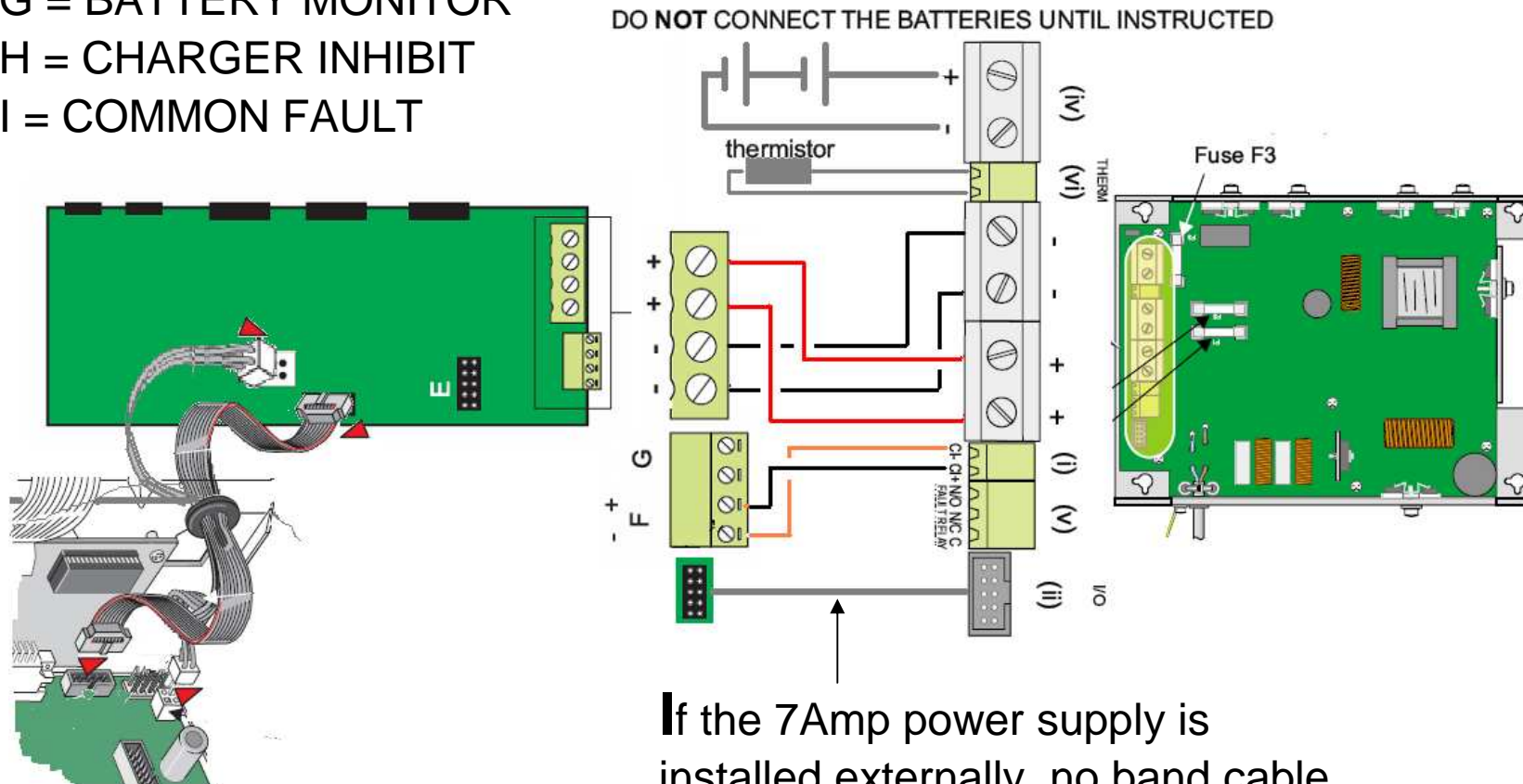

If the 7Amp power supply is installed externally, no band cable is needed between power supply and Booster!

Peripheral

Ports RS232 Fixed, RS232 Isolated and RS485

Honeywell

RS232

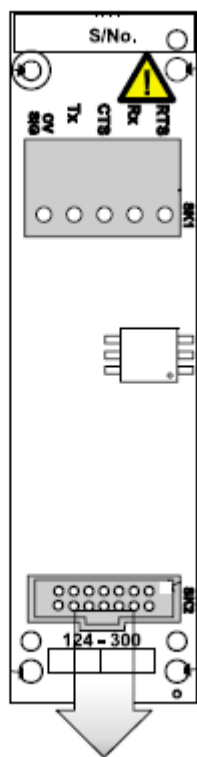

Socket SK12 or SK13 on Base PCB

- **Espa 4.4.4**
- **MGS-3000**
- **Third party**
- **Ext. Printer**
- **Isolated Diagnostic port**

Maximum cable length 15 meter by 9600 Baud.

Because the Isolated properties, ideal for third party communication and external printer (Earth connected)

RS485

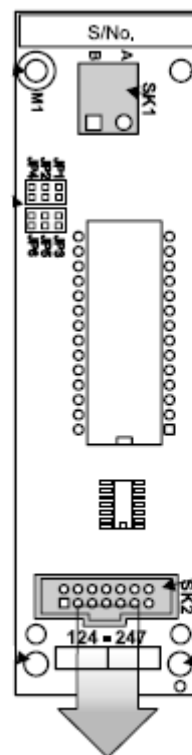

Socket SK12 or SK13 on Base PCB

- **IDR-repeaters**
- **IDR-Mimic**
- **Compact Mimic**
- **Master/Slave**
- **Third Party**

Maximum Cable length 3000 meter or 1500 meter both ways

Up to 32 peripheral devices total.

Master/Slave

1 Master 7 Slaves plus 24 peripherals

RS485 Third-Party Protocol NF3000

Honeywell

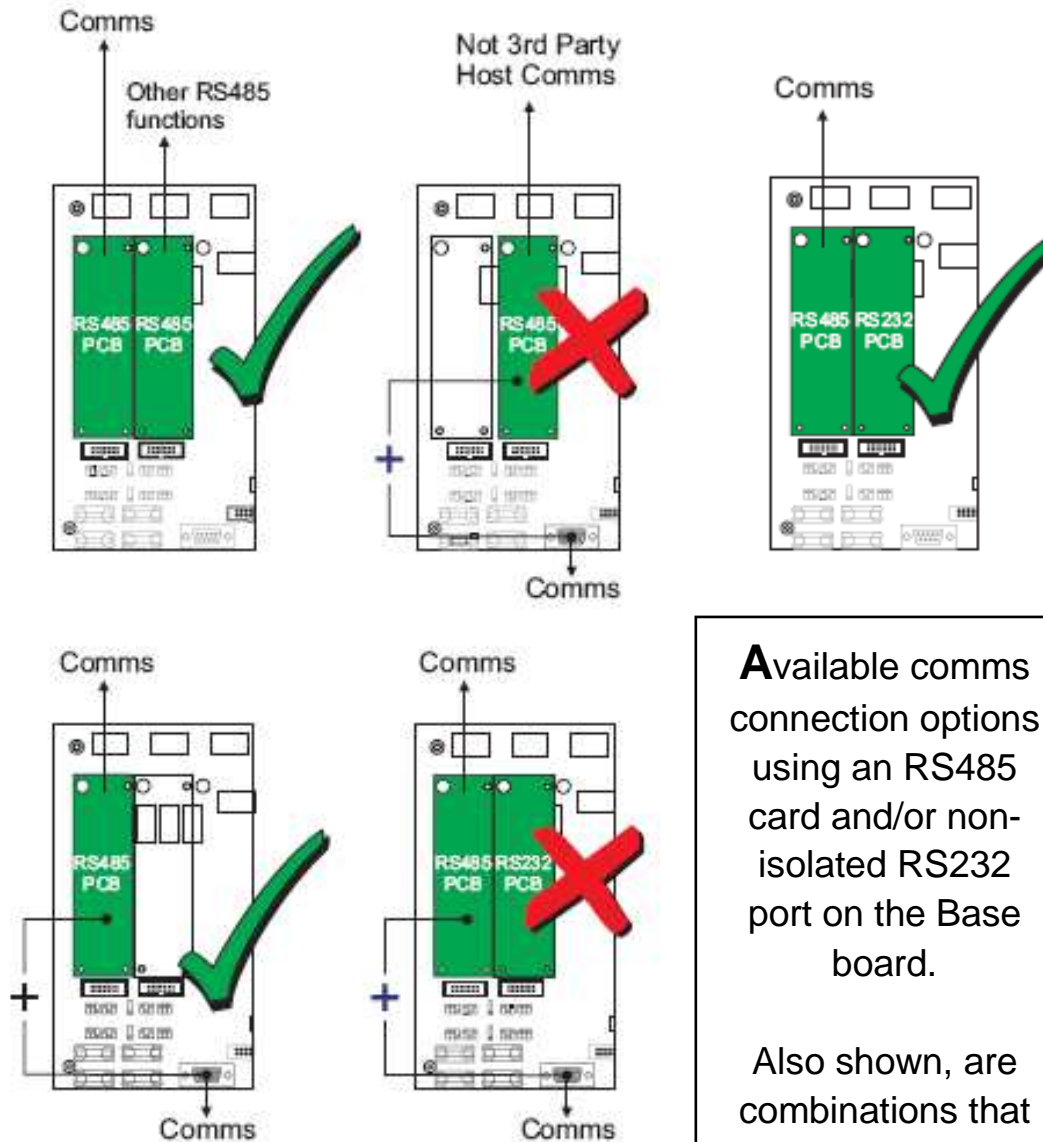

Available comms connection options using an RS485 card and/or non-isolated RS232 port on the Base board.

Also shown, are combinations that must be avoided.

maximum RS485 cards

DO NOT fit an RS232 card when an RS485 card is used for the second third-party

If two RS485 cards are fitted connect the third-party host to the left-hand card.

Only one host system may be connected to a panel (**the protocol is 'point-to-point' and not 'multi-drop'**)

The mode must be set to HALF DUPLEX. The default data rate is set to 9600 baud.

One RS485 card fitted configured for RS485 repeater or Master/Slave, any attempt to configure the RS485 for third-party protocol comms will generate a fault.



Attention,

The diagnostic port P1 is not isolated through which this is mainly arranged for diagnostic purpose

Attention,

Configure as 3th Party the access to the diagnostic/configuration port is not possible anymore.

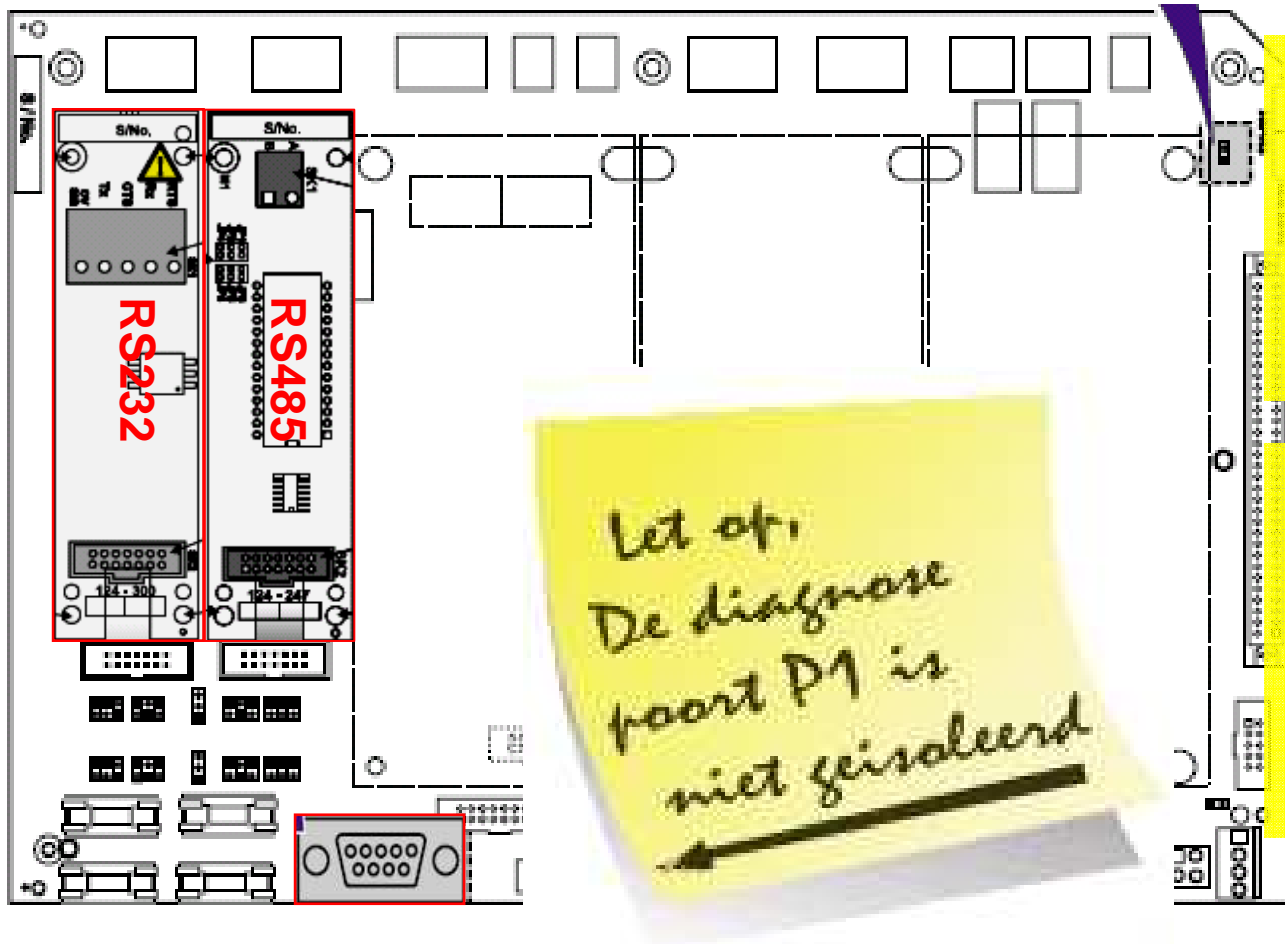

Repeaters

NF2K & NF3K



Honeywell

3 types available :

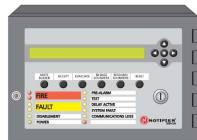

IDR-2A

IDR-2A repeater (2 x 40 display)
Can be used for NF30/50 and NF2000/NF3000 (Small display)

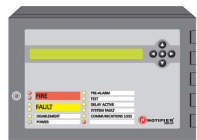

IDR-2P

IDR-2P is similar to the IDR-2A, only for system status notification
Not common used.

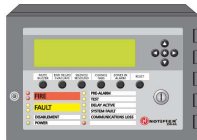

IDR-6A

IDR-6A repeater (graphics display) Ideal for use with the NF2000 and NF3000. Graphic display makes adding own logo's possible.





Importance to use an IDR-6a for NF2000 Sprinkler systems (tech. alarm indication)





Repeaters IDR-6A NF3000

MUTE BUZZER
 **Silences** repeater and panel buzzers **(locally and across the network)**, and accepts an alarm (NF2000)

END DELAY/ EVACUATE
 **Ends the delays,** Sounds all sounders configured for Evacuate.

SILENCE/ RESOUND
 Stops and restarts the sounders.

CHANGE TABS
 Steps through the tabbed displays. Displays fire alarm information.

ZONES IN ALARM
 If in alarm, steps through zones

RESET
 Restores normal operating (also over network)

LCD CONTRAST ADJUSTMENT
 Set keyswitch to right, press and hold * then press RESET momentarily. The LCD contrast cycles. Press ▶ when the contrast is satisfactory, then use ▲ and ▼ to fine-tune. Press * when finished. Contrast can also be adjusted during Lamp Test (see Section 4.5.1).

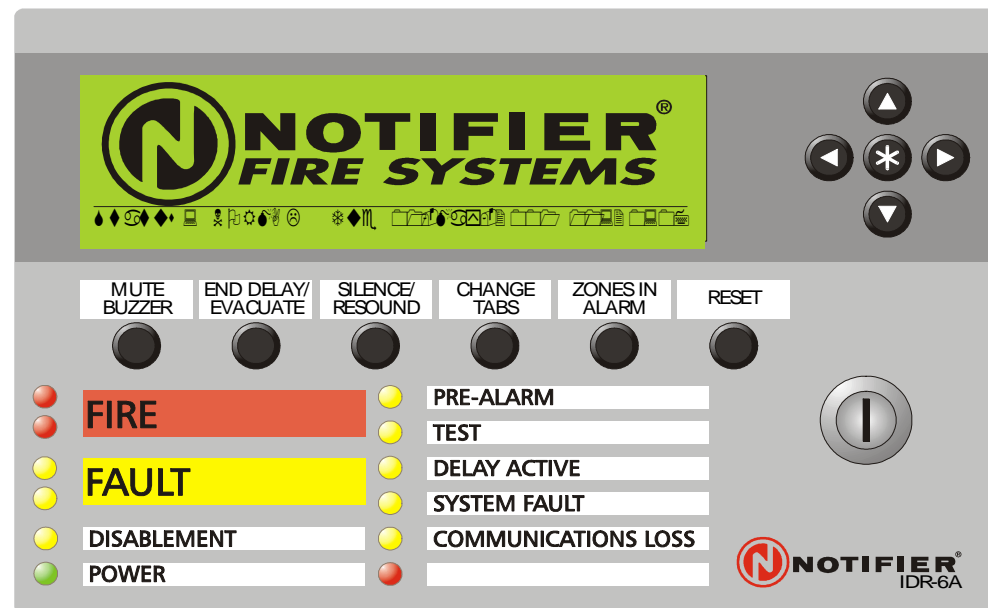

Peripherals Daisychain

NF2K & NF3K



Honeywell

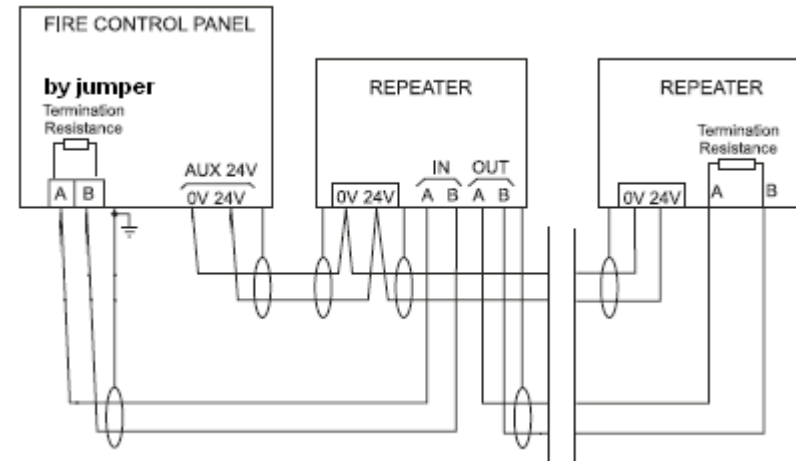
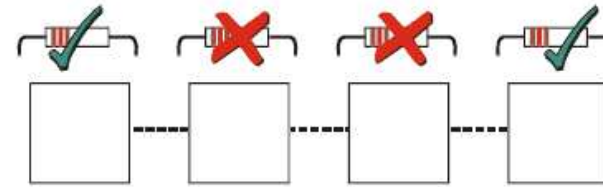
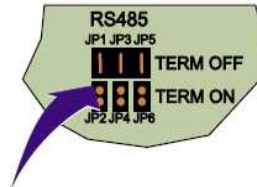
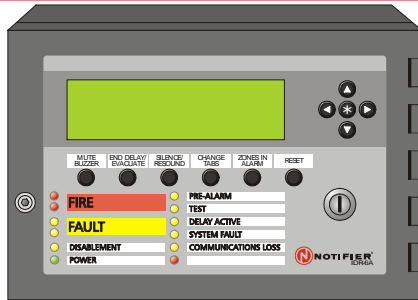

EXAMPLE MASTER/SLAVE NETWORK CONFIGURATION

Example RS485 Byte

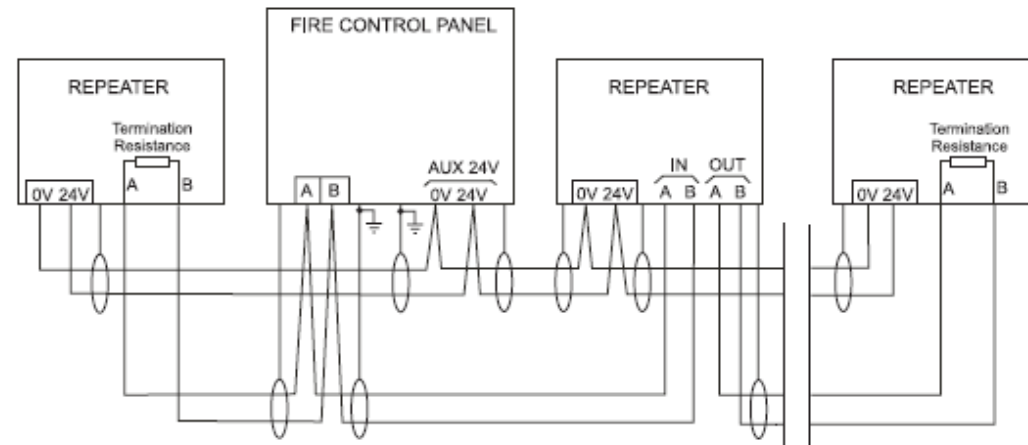
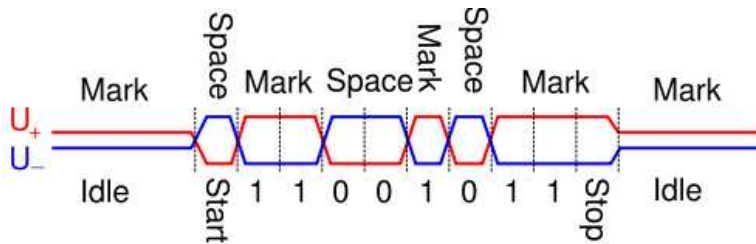

EXAMPLE MASTER/SLAVE NETWORK CONFIGURATION

Peer to Peer architecture based on Arc-net

Up to 125 stations can be networked in a loop.

Panels can be assigned to the first 32 station addresses in a non-filtered environment **or** the first 63 addresses with filtering.

Repeaters can be assigned to any address with or without filtering.

Up to 31 repeaters can be connected to a panel via its Isolated RS485 port. **These repeaters can only repeat the panel to which they are physically connected.**

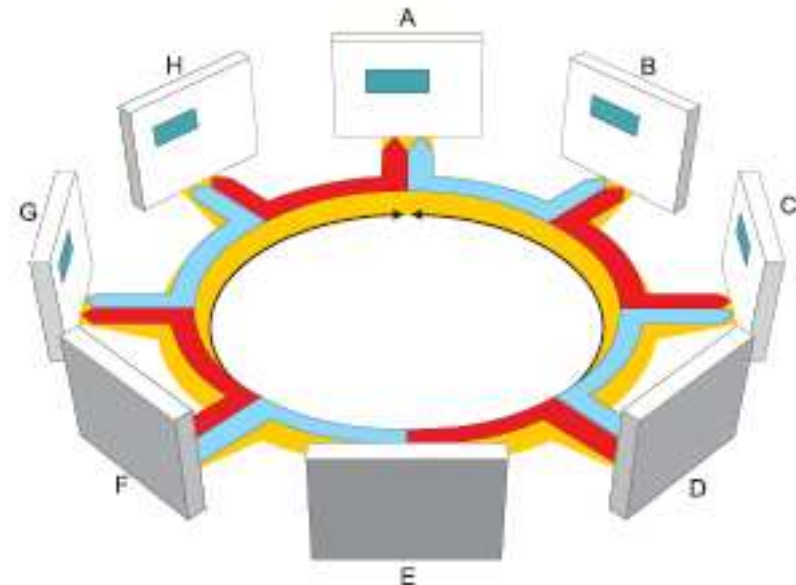
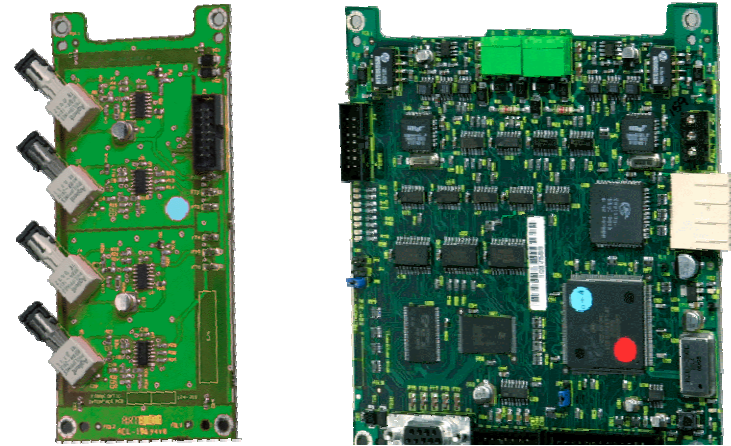

Each station has two independent peer-to-peer networks, one to either adjacent station